

iwata

by ANEST IWATA

High Performance PLUS

AIRBRUSH SERIES

Operating Instruction Manual

TOTAL CONTROL™

トータルコントロール



HP-AH



HP-BH



HP-CH



HP-TH



HP-A PLUS



HP-B PLUS



HP-SB PLUS



HP-C PLUS



HP-BC1 PLUS

Offering total control for fine detail spraying, Iwata's Hi-Line and High Performance Plus Series airbrushes are designed around the legendary Iwata HP Series which established the Iwata name in the creative community over 50 years ago. The Hi-Line Series, with its Micro Air Control Valve, enables incremental control of airflow for a fine to medium spray and creating stipple effects.

NEED ASSISTANCE ?

If you have any issues or warranty service questions, contact your local ANEST IWATA affiliate before returning to your place of purchase.

ANEST IWATA-MEDEA, INC.

Portland, Oregon U.S.A.
+1-503-253-7308 (M-F)
info@iwata-medea.com
www.iwata-airbrush.com

ANEST IWATA SOUTH-EAST ASIA CO., LTD.

Bangkok, Thailand
+66-(0)-2643-2870
www.anest-iwatasoutheastasia.com

ANEST IWATA SOUTH AFRICA (PTY) LTD.

Johannesburg, Republic of South Africa
+27-11-463-2169/2265/2223
www.anest-iwata.co.za

ANEST IWATA CORPORATION

Yokohama, Japan
+81-(0)45-591-1111
www.anest-iwata.co.jp

ANEST IWATA STRATEGIC CENTER

Cardano al Campo, Italy
+39-0331-733120
www.anest-iwataeu.com

ANEST IWATA SHANGHAI

Shanghai, China
+86-(0)21-6407-9713 / 15 / 16
www.anest-iwata-sh.com

ANEST IWATA RUS LLC

Moscow, Russia
+7-495-938-77-28
www.anestiwata.ru

ANEST IWATA AUSTRALIA PTY LTD.

Mt. Druitt, NSW
+61-(02)-9853-2000
www.anest-iwata.com.au

ANEST IWATA (U.K.) LTD.

Neots Cambs, England
+44-(0)1480-405419
www.anest-iwata.co.uk

ANEST IWATA MOTHERSON LTD.

Uttar Pradesh, India
+91-(0)120-4600500 / 14 / 17
www.aircompressors.com

CENTURY TRADING CO., LTD.

Seoul, Korea
82-2-2163-0300
www.centradng.co.kr

HIGH PERFORMANCE PLUS AIRBRUSH SERIES

- Solvent-proof PTFE needle packing
- Cutaway, preset handle
- Gravity feed configuration allows the ability to spray on just one drop of paint

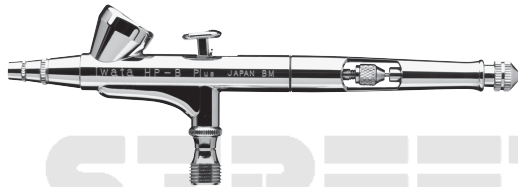

HP-B PLUS

- H2 head system
- 1/16 oz. (1.8ml) gravity feed fluid cup
- The gravity feed cup allows on-the-spot custom color mixing

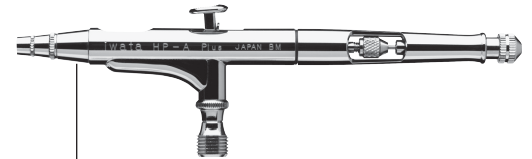

HP-A PLUS

- H2 head system
- 1/32 oz (0.9 ml) fluid cavity



HP-C PLUS

- Generous 1/3 oz. (9 ml) gravity feed cup
- H3 head system
- An airbrush that does it all - from fine hairlines to finely atomized background spray, along with an entire range of stippling effects
- The gravity feed cup allows on-the-spot custom color mixing



HP-BC PLUS

- Siphon feed configuration allows quick color changes with user-defined, stock colors
- A practical choice for most airbrush uses
- An airbrush that does it all - from fine hairlines to finely atomized background spray, along with an entire range of stippling effects
- H3 head system
- Configurable with bottles from 1oz up to 4 oz in size

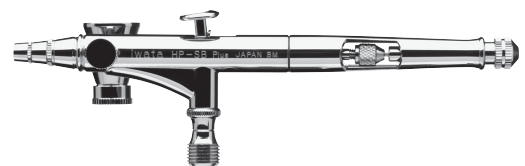

HP-SB PLUS

- H2 head system
- 1/8 oz (3.5 ml) side feed color cup
- Optional 1/4 oz. side-cup, 1/2 oz. gravity cup or a 1 oz siphon bottle add to the versatility of this airbrush
- Side feed cup configurable for right or left-handed use
- Side feed cup allows a better view of the work surface

GETTING STARTED

Compressor

Though the High Performance Plus Airbrush Series can function on minimal amounts of air, their full versatility requires an adjustable or regulated air source with an air storage tank. Other compressor considerations include the length of use while spraying and the environment, or amount of space, you spray in.

These Iwata Studio Series models come equipped with an air regulator for precise air adjustment:

- Smart Jet Pro: Good for small studios and normal use.
- Power Jet Lite: Good for normal studios and extended use.
- Power Jet: Great for normal studios and great for extended use.
- Power Jet Pro: Great for normal studios and great for extended use.
(Two regulators allow two airbrushes on same unit.)

Assembly

1. Screw the airhose onto the compressor.
2. Screw the airhose onto the airbrush.
3. If using a Smart Jet Pro, Power Jet, Power Jet Lite, or Power Jet Pro compressor, adjust the pressure to between 10 and 15 psi.
4. Check for any air leaks in the compressor or airhoses.
5. Place a few drops of cleaning solution or water into the airbrush's bowl.
6. Point the airbrush away from you.
7. Press down on the main lever (#7) to start airflow through the airbrush.
8. Pull the main lever back opening the airbrush's nozzle.
9. Spray water through the airbrush to see how it sprays.

GENERAL OPERATION

Wide-Lines and Blending

1. Depress the main lever (#7).
2. Position the airbrush from 1/2 to 6 inches away from the surface.
3. Pull the main lever back much further to release more paint to cover the bigger area.
 - A longer distance to the paint surface produces wider lines.
 - A shorter distance to the paint surface produces narrower lines.
 - Increased air pressure increases spray width.
 - Decreased air pressure decreases spray width.
 - The maximum usable line width is approximately 2 inches.

Preset Handle (#17)

A threaded adjusting screw mounted behind the handle limits the distance the main lever can be pulled back. This provides accurate paint volume control and is especially useful for repetitive, precision work.

Cutaway Handle

The cutaway handle allows quick paint clog removal without removing the handle or needle.

1. Grip the exposed needle chucking nut (#16) with your fingers.
2. Pull it back while simultaneously depressing the main lever (#7).
3. Repeat this process several times until the airbrush is clog free and spraying normally.
 - The increased paint flow past needle and nozzle tip removes many clogs.
 - Don't let the needle "snap" back into place. This could damage the nozzle.

Stippling

Iwata airbrushes are designed to produce a wide range of stippling textures.

1. Unscrew the needle cap (#1).
2. Unscrew the nozzle cap (#2).
3. Adjust the air pressure between 8 and 60 psi.
 - Low air pressure creates coarse stipples.
 - High air pressure provides fine stipple effects.
 - Paint viscosity also effects stippling texture.

Air Pressure

Working pressures generally vary between 8 and 60 psi, depending on the type of surface, the desired spray texture, and the paint's viscosity.

Start spraying with 15 psi. If the spray is too grainy adjust the pressure up until the desired spray consistency is reached.

- Different colors will behave differently.
- Different paint lines will behave differently.
- Spray thick paint with greater pressure.
- Spray thin paint with less pressure.
- Spray large paint amounts with greater pressure.
- Spray small paint amounts with less pressure.

WARNING: Do not exceed 98psi.

Paint Preparation

For non-specific airbrush paints, proper preparation, including filtering the paint through a nylon mesh, is critical for best performance. Thin paint with its proper solvent, and make repeated passes across the work to build up the color. This improves your work's quality and decreases your airbrush's cleaning time.

- Airbrushes spray very thin paint easiest.
- Thin paint with its proper solvent.
- Filter paint through paint filters or mesh.

Safety Tips

- Always spray in well ventilated areas.
- Do not spray solvent based (flammable) paints around open flames.
- Use the appropriate respirator to safely filter out paint vapors particular to your specific paint type.
- Wear eye protection to prevent paint contact with eyes.
- Never exceed the airbrush's pressure limit (98 psi).

**Cleaning the Airbrush Between Colors
(A+, B+, C+, SB+ Only)**

1. Dump out the color cup's excess paint.
2. Rinse the cup with the appropriate cleaning solution.
3. Use a paper towel to wipe out any left over paint.
4. Fill the bottom of the cup with cleaner.
5. Spray cleaner until the spray is clear.
6. Add the next color to the color cup.
7. Repeat cleaning procedure when finished.

**Cleaning the Airbrush Between Colors
(BC+ Only)**

1. Remove the paint bottle.
2. Attach a bottle containing the appropriate cleaning solution.
3. Spray until the solution sprays clear.
4. Remove the bottle of cleaning solution.
5. Spray air until the airbrush sprays dry.
6. Attach a bottle containing the next color.
7. Repeat cleaning procedure when finished.

Cleaning the Needle (#4)

1. Unscrew the handle (#17) from the airbrush body.
2. Loosen the needle chucking nut (#16).
3. Gently pull the needle (#4) straight out.
4. Fold a soft cloth damp with cleaner over the needle.
5. Rotate the needle to gently wipe the residual paint off.
6. Carefully insert the needle into the airbrush until it seats fully against the nozzle (#3). You should feel a positive stop. If you feel a spongy stop, you still have debris in your nozzle.

CAUTION: The most probable time to damage the needle is when the needle passes through the main lever (#7) and through the needle packing screw (#5).

If the needle stops abruptly, retract and examine the trigger mechanism for proper assembly and re-insert the needle.

7. Tighten the needle chucking nut finger tight.
 - Pull the main lever back and forth to visually confirm the needle's ability to move.
8. Screw the handle back onto the airbrush body.

Before Each Session

Spray water or the appropriate paint solvent through the airbrush to make sure the airbrush is working properly.

After Each Session

Or any time the airbrush becomes clogged.

1. Increase the air pressure.
2. Spray cleaning solution for a short time.
3. Clean the needle if necessary

This cleaning method helps clean the paint passage, the nozzle, and the needle thoroughly.

Lubricating the Needle (#4)

To ensure smooth main lever (#7) action lubricate the needle when the trigger won't respond properly.

1. Unscrew the handle (#17).
2. Loosen the needle chucking nut (#16).
3. Remove the needle.
4. Coat the needle slightly with Medea Super Lube starting 1 inch behind the tip.
5. Wipe the needle with a soft, clean cloth, leaving a light coat of lube behind.
6. Re-insert the needle gently into the airbrush until you feel a positive stop.
7. Tighten the needle chucking nut.
8. Screw the handle onto the airbrush body.

DO NOT over-lube the needle; transferring excess lube into the nozzle may cause severe paint flow problems.

DO NOT use light machine oil or WD-40 for lubrication. These lubes cause the needle to stick when it moves through the needle packing o-ring and can also get into the air system.

CAUTION: If it becomes absolutely necessary to dismantle the airbrush remember that most situations do not require tools.

DO NOT use pliers.

 **NEVER soak your entire airbrush in any liquid. NEVER store your airbrush with spray medium or cleaning agents in the fluid cup.**

Lubricating the Air Piston (#12)

(A+, B+, C+, SB+ Only)

To ensure smooth main lever (#7) action lubricate the air piston when the trigger won't respond properly.

1. Unscrew the handle (#17).
2. Unscrew the needle chucking nut (#16).
3. Remove the needle (#4).
4. Unscrew the spring guide (#11).
5. Remove the needle spring (#10).
6. Remove the needle chucking guide (#9).
7. Pull the main lever up and out.
8. Use tweezers to pull out the air valve piston.
9. Clean the air piston with a cotton swab.
10. Clean the hole at the bottom of the trigger housing with a cotton swab.
 - a. Clean until a Cotton Swab comes back clean.
11. Dab a very small drop of Super Lube on the air piston shaft.
12. Insert the air piston back into the hole at the bottom of the trigger housing.
13. Place the main lever back into the trigger housing.
14. Press the main lever up and down a few times.
 - a. It should spring back up smoothly when depressed.
15. Place the needle chucking guide into the airbrush body.
 - a. Check the parts guide for proper orientation.
 - b. Pull the small tab forward.
 - c. Angle the needle chucking guide's tail end slightly up.
 - d. Insert the needle chucking guide into the airbrush body.
 - e. The small tab should stick up slightly behind the main lever.
16. Place the needle spring over the needle chucking guide.
17. Screw the spring guide into the airbrush body.
18. Push down on the main lever at least once.
19. Carefully insert the needle. **Warning: This is the most probable time to bend the needle point.**
20. Screw the needle chucking nut onto the needle chucking guide.
21. Screw the handle back into the airbrush body.

DO NOT over-lube the air piston; transferring excess lube into the air system may cause severe paint flow problems.

DO NOT use light machine oil or WD-40 for lubrication. These lubes cause the needle to stick when it moves through the needle packing o-ring.

CAUTION: If it becomes absolutely necessary to dismantle the airbrush remember that most situations, unless otherwise directed, do not require tools.

**Lubricating the Air Piston (#12)
(BC+ Only)**

1. Unscrew the handle (#17).
2. Unscrew the needle chucking nut (#16).
3. Remove the needle (#4).
4. Unscrew the spring guide (#11).
5. Remove the needle spring (#10).
6. Remove the needle chucking guide (#9).
7. Pull the main lever up and out.
8. Clean the air piston, the main lever's dangly piece with a cotton swab.
9. Clean the hole at the bottom of the trigger housing with a cotton swab.
 - a. Clean until a cotton swab comes back clean.
10. Dab a very small drop of Super Lube on the air piston shaft.
11. Straighten the air piston and the main lever out.
12. Insert the air piston back into the hole at the bottom of the trigger housing.
13. Place the main lever back into the trigger housing.
14. Press the main lever up and down a few times.
 - a. It should spring back up smoothly when depressed.
15. Place the needle chucking guide into the airbrush body.
 - a. Check the parts guide for proper orientation.
 - b. Pull the small tab forward.
 - c. Angle the needle chucking guide's tail end slightly up.
 - d. Insert the needle chucking guide into the airbrush body.
 - e. The small tab should stick up slightly behind the main lever.
16. Place the needle spring over the needle chucking guide.
17. Screw the spring guide into the airbrush body.
18. Push down on the main lever at least once.
19. Carefully insert the needle. **Warning: This is the most probable time to bend the needle point.**
20. Screw the needle chucking nut onto the needle chucking guide.
21. Screw the handle back into the airbrush body.

DO NOT over-lube the air piston; transferring excess lube into the air system may cause severe paint flow problems.

DO NOT use light machine oil or WD-40 for lubrication. These lubes cause the needle to stick when it moves through the needle packing o-ring.

CAUTION: If it becomes absolutely necessary to dismantle the airbrush remember that most situations, unless otherwise directed, do not require tools.

TROUBLESHOOTING PROCEDURES

| SYMPTOM | PROBLEM | SOLUTION |
|------------------------------------|---|---|
| Bubbles in Color Cup or Bottle | Loose nozzle cap | Tighten nozzle cap (#1B) finger tight |
| | Improper nozzle to head nozzle base connection* | See head system (#1) to reseal the nozzle |
| | Cracked or damaged nozzle | See head system (#1) to replace the head system |
| Double Line | Dried paint on needle tip (tip-dry) | See Cleaning the Needle |
| | Dirty airbrush | See Cleaning the Airbrush Between Colors See Cleaning the Needle |
| | Debris on nozzle tip | See head system (#1) and clean the nozzle (#1C) |
| | Bent needle | See needle (#10) to replace needle |
| | Cracked or damaged nozzle | See head system (#1) to replace the head system |
| Not Spraying | Loose needle chucking nut | Finger tighten |
| | Needle stuck | Pull out / break free the needle |
| | Improper air pressure | See specific compressor instructions to raise or lower the air pressure |
| | Paint too thick | See Paint Preparation |
| | Clogged nozzle | See head system (#1) and clean the nozzle (#1C) |
| | Cracked or damaged nozzle | See head system (#1) to replace the head system |
| Skipping | Dried paint on needle tip (tip-dry) | See Cleaning the Needle (page <?>) |
| | Paint too thick | See Paint Preparation (page <?>) |
| | Improper nozzle to head nozzle base connection* | See head system (#1) to reseal the nozzle |
| | Dirty airbrush | See Cleaning the Airbrush Between Colors (page <?>) See Cleaning the Needle (page <?>) |
| | Cracked or damaged nozzle | See head system (#1) to replace the head system |
| Spattering | Dried paint on needle tip (tip-dry) | See Cleaning the Needle |
| | Paint build-up in crown cap | Unscrew (#1A) and clean |
| | Air pressure too low | See specific compressor instructions to raise the air pressure |
| | Paint too thick | See Paint Preparation |
| | Dirty airbrush | See Cleaning the Airbrush Between Colors See Cleaning the Needle |
| Main Lever Sticks (Back and Forth) | Dirty airbrush | See Cleaning the Airbrush Between Colors See Cleaning the Needle |
| Main Lever Sticks (Up and Down) | Paint on air valve packing o-ring (#14B) | See Lubricating the Air Valve O-Ring |

CAUTION

* The most likely time to damage the nozzle (#1C) is upon removal from the airbrush. Because the head system can be removed entirely, the nozzle does not need to be removed at all. If the nozzle is never removed, you do not have to worry about "improper nozzle to head nozzle base connections".

Nozzle contains Nickel.

IWATA HIGH PERFORMANCE PLUS AIRBRUSH SERIES
HP-A+ / HP-B+ / HP-SB+ / HP-C+ / HP-BC+

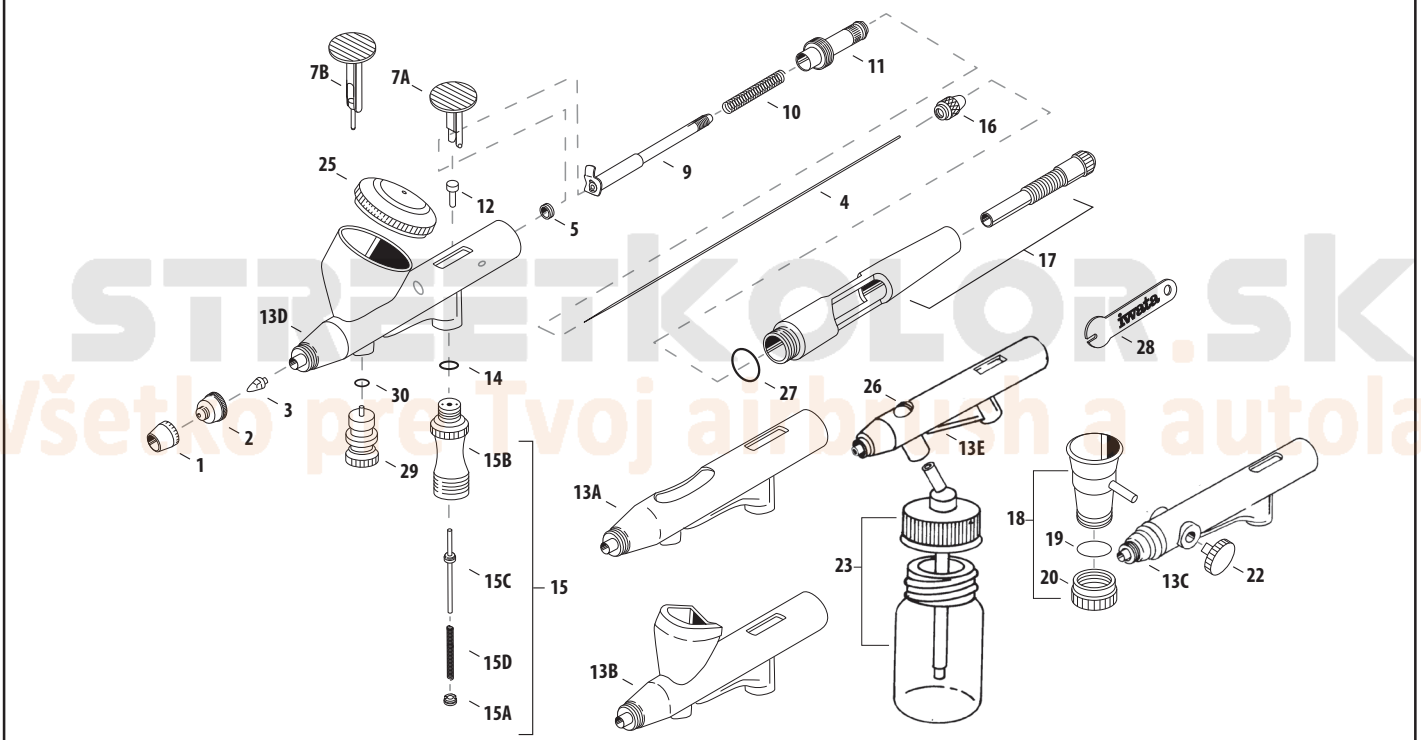

| # | ITEM DESCRIPTION | PRICE CODE | ITEM # | HP-A+ | HP-B+ | HP-SB+ | HP-C+ | HP-BC+ |
|-----|--|------------|---------|-------|-------|--------|-------|--------|
| 1 | Needle Cap | H2 | B I1101 | ■ | ■ | ■ | x | x |
| | | H3 | B I1102 | x | x | x | ■ | ■ |
| 2 | Nozzle Cap | H2 | D I1401 | ■ | ■ | ■ | x | x |
| | | H3 | D I1403 | x | x | x | ■ | ■ |
| 3 | Nozzle | H2 | G I0807 | ■ | ■ | ■ | x | x |
| | | H3 | G I0808 | x | x | x | ■ | ■ |
| 4 | Needle | H2 | C I0751 | ■ | ■ | ■ | x | x |
| | | H3 | C I0753 | x | x | x | ■ | ■ |
| 5 | Needle Packing Screw Set (PTFE) | B | I1257 | ■ | ■ | ■ | x | x |
| | | B | I7251 | x | x | x | ■ | ■ |
| 7A | Main Lever | D | I1001 | ■ | ■ | ■ | x | x |
| | | D | I1002 | x | x | x | ■ | x |
| 7B | Main Lever | G | I1003 | x | x | x | x | ■ |
| 9 | Needle Chucking Guide with Auxiliary Lever | C | I1157 | ■ | ■ | ■ | x | x |
| | | C | I7151 | x | x | x | ■ | ■ |
| 10 | Needle Spring | A | I1352 | ■ | ■ | ■ | x | x |
| | | A | I1353 | x | x | x | ■ | ■ |
| 11 | Spring Guide | C | I1706 | ■ | ■ | ■ | x | x |
| | | A | I7701 | x | x | x | ■ | ■ |
| 12 | Valve Piston | A | I1751 | ■ | ■ | ■ | ■ | x |
| 13A | HP-A Plus Body* | - | - | ■ | x | x | x | x |
| 13B | HP-B Plus Body* | - | - | x | ■ | x | x | x |
| 13C | HP-SB Plus Body* | - | - | x | x | ■ | x | x |
| 13D | HP-C Plus Body* | - | - | x | x | x | ■ | x |
| 13E | HP-BC Plus Body* | - | - | x | x | x | x | ■ |
| 14 | Air Valve O-ring | A | I1451 | ■ | ■ | ■ | ■ | ■ |

| # | ITEM DESCRIPTION | PRICE CODE | ITEM # | HP-A+ | HP-B+ | HP-SB+ | HP-C+ | HP-BC+ |
|-----|--|------------|--------|-------|-------|--------|-------|--------|
| 15 | Air Valve Set | G | I0301 | ■ | ■ | ■ | x | x |
| | | G | I0304 | x | x | x | ■ | ■ |
| 15A | Air Valve Guide | A | I0251 | ■ | ■ | ■ | ■ | ■ |
| 15B | Air Valve Body | D | I0201 | ■ | ■ | ■ | ■ | ■ |
| 15C | Air Valve | B | I0151 | ■ | ■ | ■ | x | x |
| | | B | I0154 | x | x | x | ■ | ■ |
| 15D | Air Valve Spring | A | I0351 | ■ | ■ | ■ | ■ | ■ |
| 16 | Needle Chucking Nut | A | I1201 | ■ | ■ | ■ | ■ | ■ |
| 17 | Preset Handle Set | G | I1555 | ■ | ■ | ■ | x | x |
| | | G | I1556 | x | x | x | ■ | ■ |
| 18 | Cup (Side) 0.05 oz / 1.50 ml | G | I0703 | x | x | ■ | x | x |
| 19 | Cup Packing Lower Lid | A | I1505 | x | x | ■ | x | x |
| 20 | Cup Lower Lid 0.05 oz / 1.50 ml | B | I0956 | x | x | ■ | x | x |
| 22 | Blanking Cover | A | I0452 | x | x | ■ | x | x |
| 23 | Glass Bottle Set 0.75 oz / 20 ml | G | I4052 | x | x | x | x | ■ |
| 25 | Fluid Cup Lid | C | I6181 | x | x | x | ■ | x |
| 26 | Blanking Screw | B | I0451 | x | x | x | x | ■ |
| 27 | Packing Handle (O-ring) | A | I6051 | ■ | ■ | ■ | ■ | ■ |
| 28 | Spanner | A | I1651 | ■ | ■ | ■ | ■ | ■ |
| | Needle Crown Cap | D | I1050 | OPT | OPT | OPT | OPT | OPT |
| | QuickFit Quick Disconnect Set | H | I1603 | OPT | OPT | OPT | OPT | OPT |
| | QuickFit Quick Disconnect Airbrush Adaptor | C | I1604 | OPT | OPT | OPT | OPT | OPT |
| | Airbrush Adaptor for Paasche Air Hose | - | J001 | OPT | OPT | OPT | OPT | OPT |
| | Airbrush Adaptor for T&C/Badger Air Hoses | - | J002 | OPT | OPT | OPT | OPT | OPT |

■ = yes x = no OPT = optional
*Replacement parts not available.

REPLACEMENT PARTS AND ACCESSORIES

Nozzle (#3)

In time, the nozzle may wear or be damaged and may need to be replaced.

1. Unscrew the handle (#17).
 2. Loosen the needle chucking nut (#16).
 3. Gently pull the needle (#4) part way back. It doesn't need to be fully pulled out.
 4. Unscrew the nozzle cap (#2).
 5. Unscrew the nozzle counter-clockwise with the provided wrench.
 6. Screw the new nozzle into the airbrush body with your fingers.
 7. Slightly tighten the nozzle with wrench. **DO NOT OVERTIGHTEN!**
 8. Screw the nozzle cap onto the airbrush body.
 9. Push the needle all the way forward until it seats with the new nozzle.
 10. Tighten the needle chucking nut.
 11. Screw the handle onto the airbrush body.
- TIP: Keep a spare nozzle on hand for unforeseen accidents.

Needle (#4)

Iwata needles are precision ground, hardened stainless- steel capable of withstanding prolonged use. They are, however, easily physically damaged because of the long, tapered, extremely fine tip. If the needle point becomes severely bent, it must be straightened before pulling it back through the nozzle. If not, the bent needle might damage the nozzle as it's pulled through.

TIP: Keep a spare needle on hand for unforeseen accidents.

- Needles are sharp.
- Needle tips are bent easily.



Nozzle contains Nickel.

Crown Cap (Optional Accessory)

The crown cap physically protects the needle while spraying very fine lines. It also adds to pigment build-up and spattering when spraying large backgrounds.

- Protects the needle
- Replaces the needle cap (#1)
- Adds to pigment build-up and spattering effects over large areas

Quick Disconnect (Optional Accessory)

A quick disconnect joint is screwed onto the airhose and a quick disconnect adapter is screwed onto each airbrush. When using multiple airbrushes the quick disconnect joint facilitates changing airbrushes on the same airhose quickly.

Pistol-Grip Moisture Filter (Optional Accessory)

The Iwata Pistol-Grip Moisture Filter delivers clean, dry air to your airbrush. Miniature in size, the super-fine, 5-micron filter element performs like a full-size filter separator.

The clear filter bowl allows visual inspection of built up moisture. Release the water by pulling the spring-loaded release valve.

WARRANTY



All Iwata airbrushes are warranted against all manufacturing defects of material and manufacture or workmanship for a period of FIVE years from date of purchase. This warranty does not cover needles, nozzles, o-rings and internal packings since these parts need to be replaced occasionally due to normal wear. Any other parts or materials that are or become defective so as not to be usable within this period will be repaired or replaced. This warranty does not cover damage caused by negligence or airbrushes which have been altered or abused in any way.

iwata

by ANEST IWATA

www.iwata-airbrush.com